

# CLASSIC 290

# SPECIFICATIONS

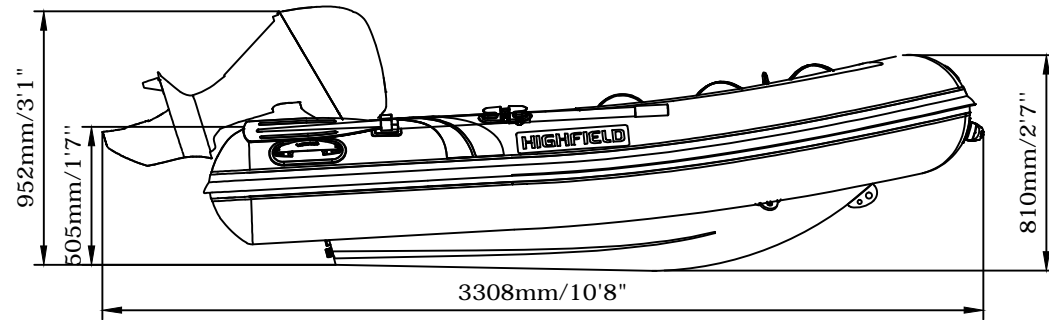

Side View

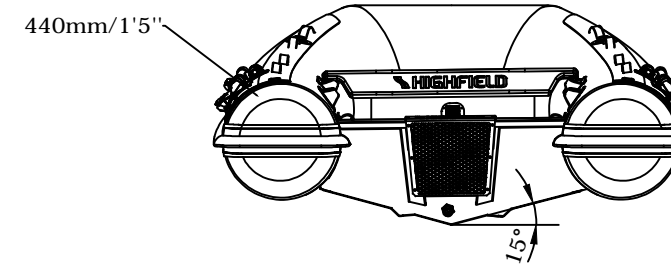

Rear View

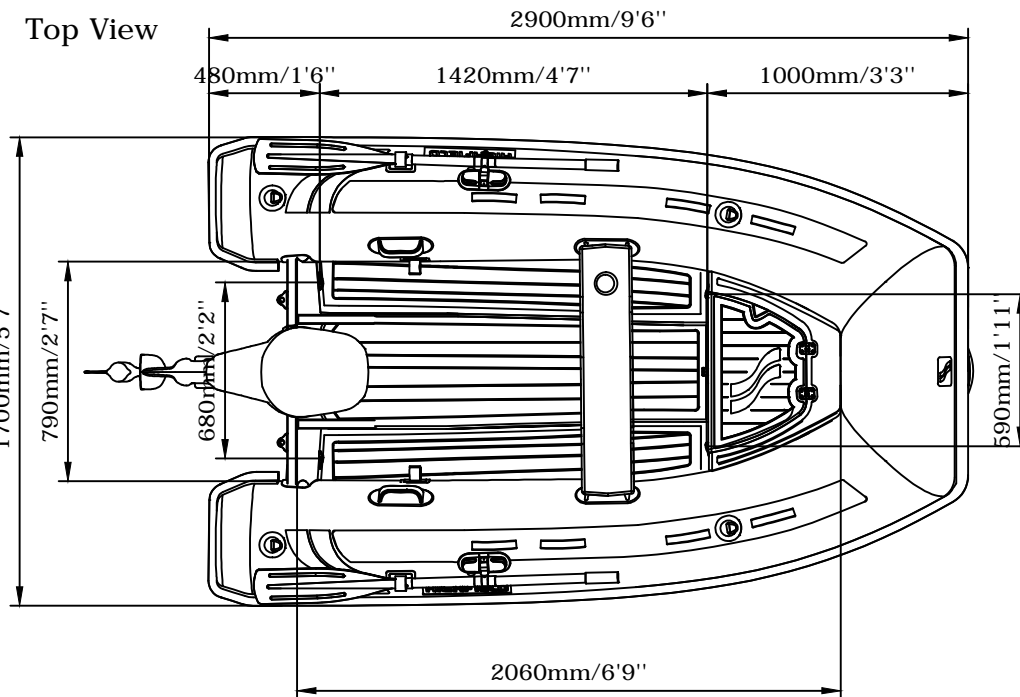

Top View

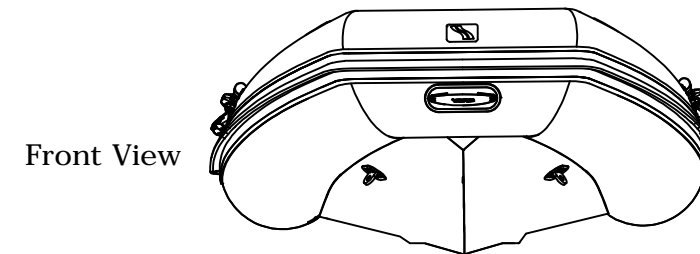

Front View

SPECIFICATIONS AND MAXIMUM CAPACITIES (Subject to change without notice. Tolerances: Dimensions +/-3% Weight +/-5%)

| MODEL | ISO 6185 PART | ISO 6185 |     |      | # |     |     | <br>Maximum Speed |    |             |       |               |       |    |    | <br>Wet Weight (Approximate)<br>15HP (11.19KW)<br>+ Fuel |      | AIR CHAMBERS |     |     |     |   |      |      |
|-------|---------------|----------|-----|------|---|-----|-----|-------------------|----|-------------|-------|---------------|-------|----|----|--|------|--------------|-----|-----|-----|---|------|------|
|       |               |          | KG  | LB   |   | KG  | LB  | Maximum           |    | Recommended |       | Maximum Speed |       | KG | LB | KG   | LB   |              | PSI | BAR |     |   |      |      |
|       |               |          |     |      |   |     |     | Length            | KG | LB          | KW    | HP            | KW    | HP | KT | MPH  | Km/h |              |     |     |     |   |      |      |
| CL290 | 2             | C        | 480 | 1058 | 4 | 300 | 661 | S                 | 60 | 132         | 14.92 | 20            | 11.19 | 15 | /  | /  | /    | 59           | 130 | 119 | 262 | 3 | 3.63 | 0.25 |

Weight: Boat only, not including molded seat, oars and other accessories.