

OCEAN MASTER 350

SPECIFICATIONS

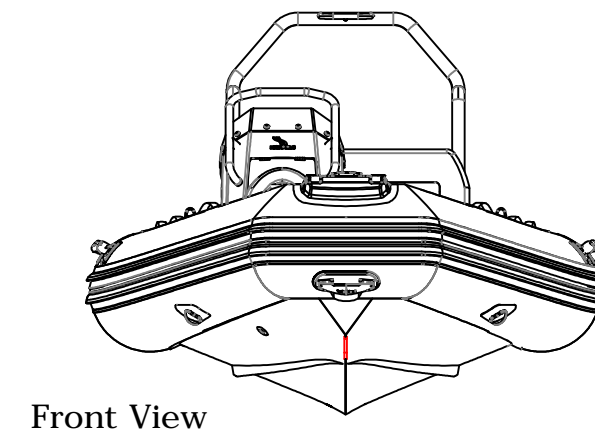
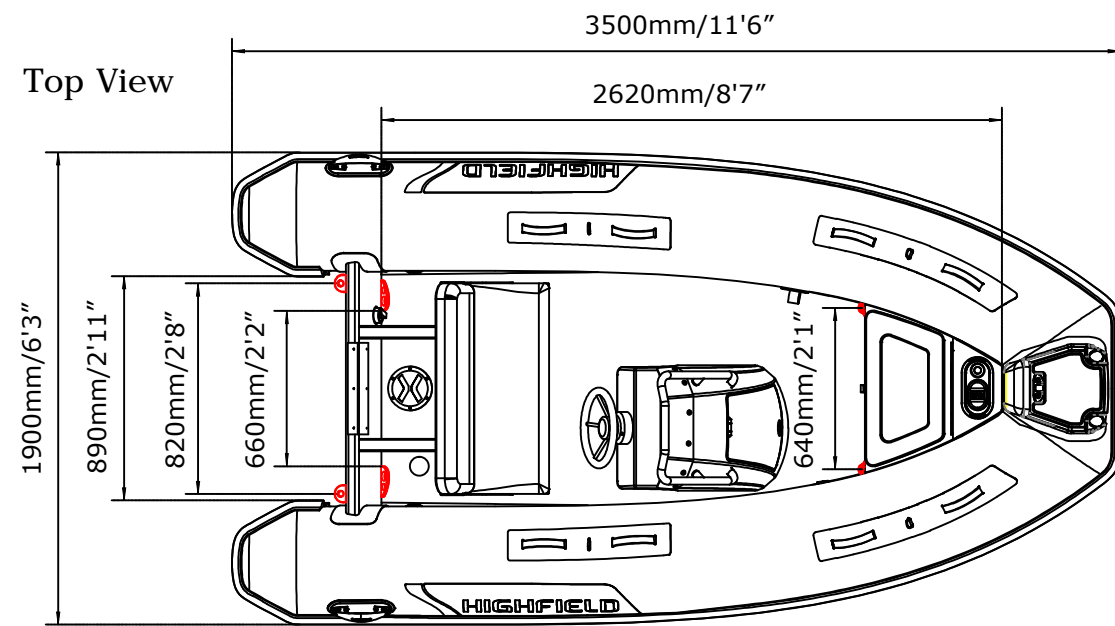
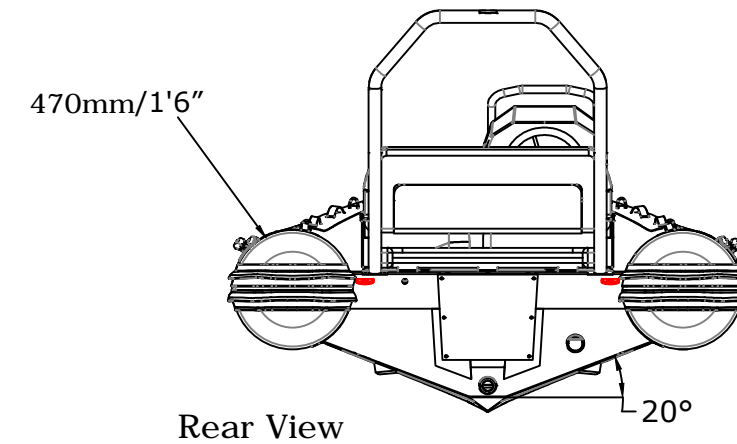
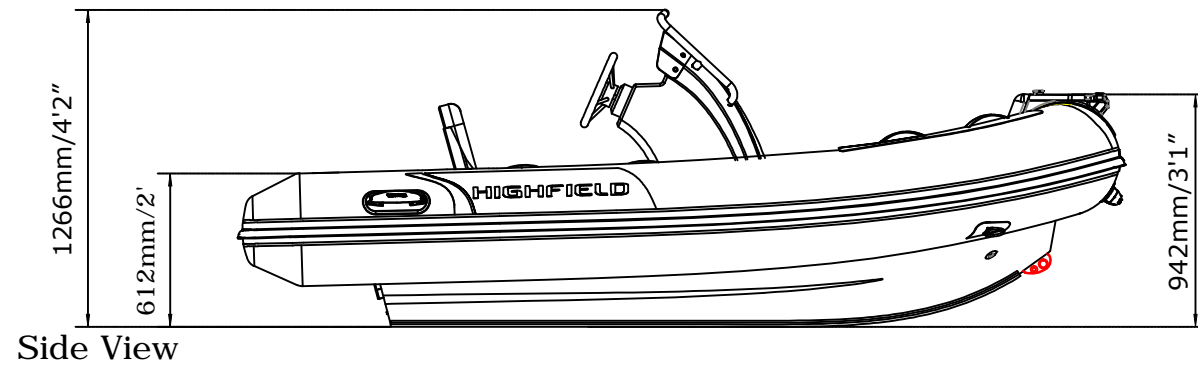

MODEL	ISO 6185 PART	ISO 6185			#												Wet Weight (Approximate) 40HP (30KW) + Fuel		AIR CHAMBERS					
			KG	LB		KG	LB	Length	KG	LB	Maximum		Recommended			Maximum Speed	KG	LB		KG	LB	PSI	BAR	
												KW	HP	KW	HP		KT	MPH						Km/h
OM350	3	C	628	1385	6	450	992	L	124.1	274	29.84	40	22.38	30	/	/	/	162	357	308.1	679.2	3	3.63	0.25

Weight includes: console ,seat ,rollbar