

OCEAN MASTER 540

SPECIFICATIONS

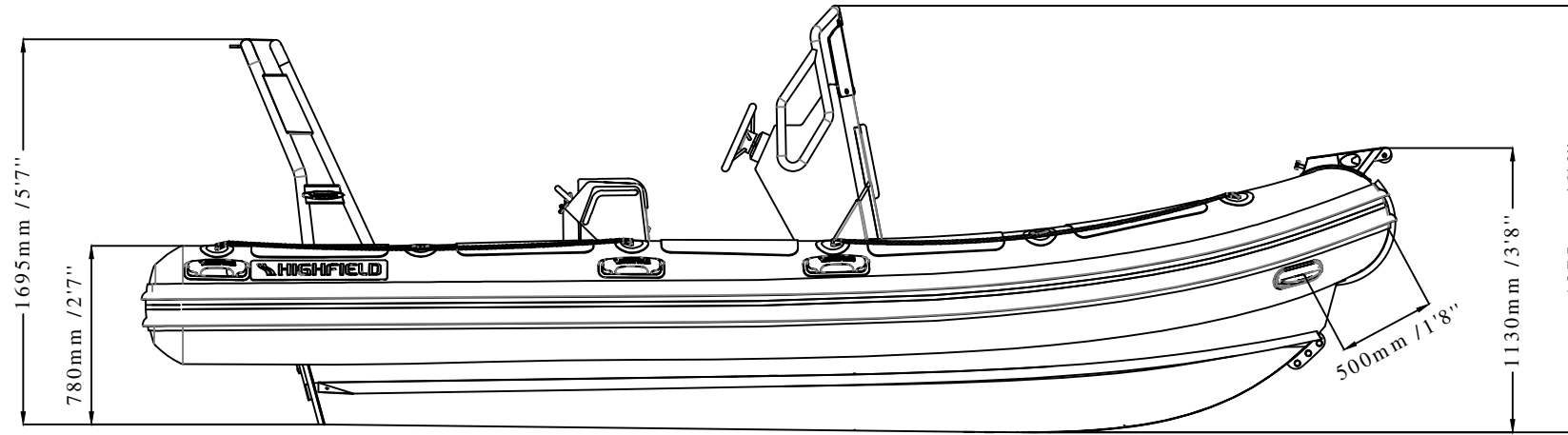

Side View

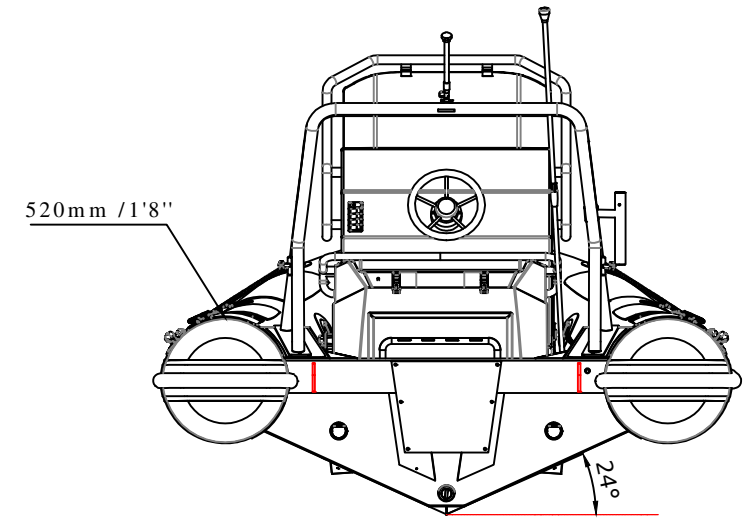

Rear View

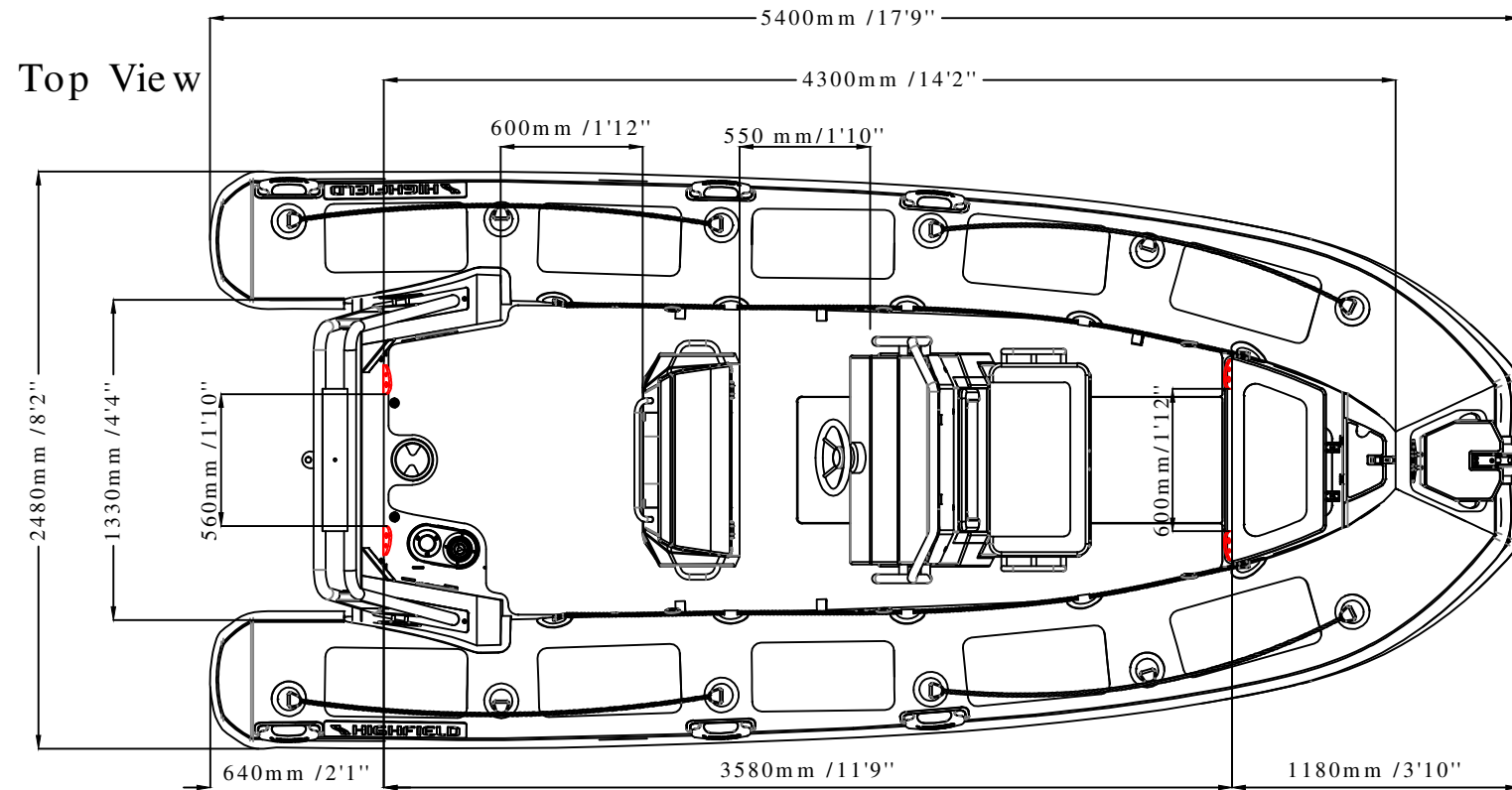

Top View

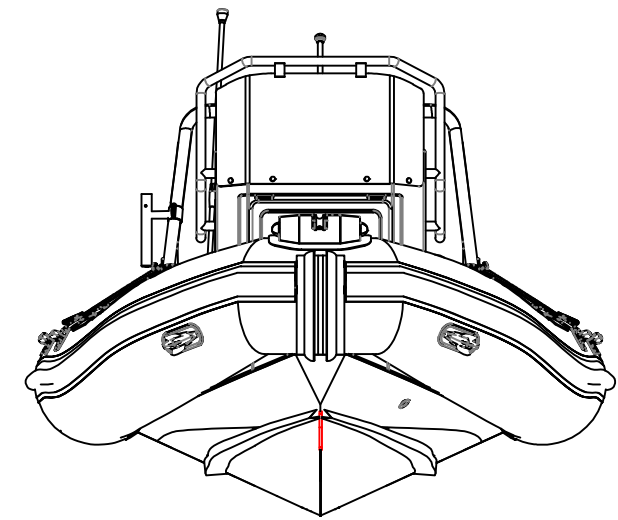

Front View

SPECIFICATIONS AND MAXIMUM CAPACITIES (Subject to change without notice. Tolerances: Dimensions +/-3% Weight +/-5%)

MODEL	ISO 6185 PART	ISO 6185			#			Length							Wet Weight (Approximate) 115HP (85.79KW) + Fuel		AIR CHAMBERS							
			KG	LB		KG	LB		Maximum	Recommended	Maximum Speed	KG	LB	KG	LB	PSI		BAR						
									KW	HP	KW	HP	KT	MPH	Km/h									
OM540	3	C	1262	2782	12	900	1989	XL	258.6	570	85.79	115	67.14	90	/	/	/	494	1036	828.7	1827	6	3.63	0.25

Weight includes: console, seat, rollbar