

OCEAN MASTER 500

SPECIFICATIONS

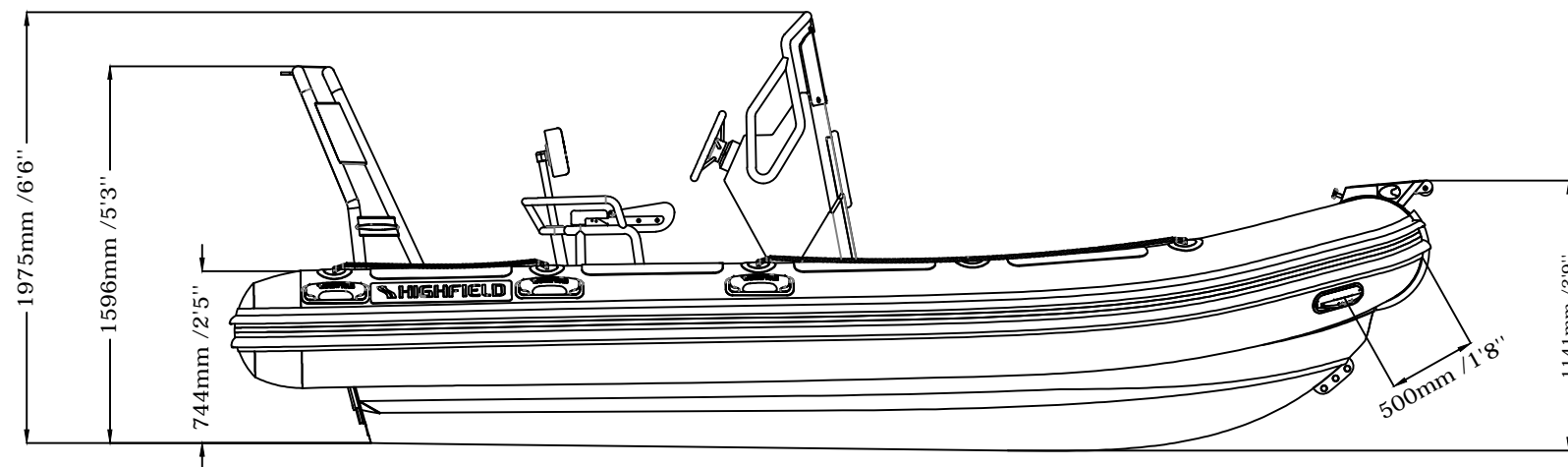

Side View

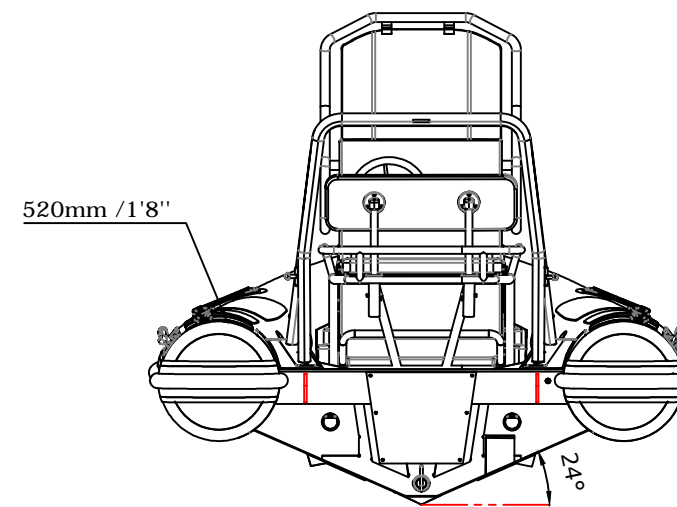

Rear View

Top View

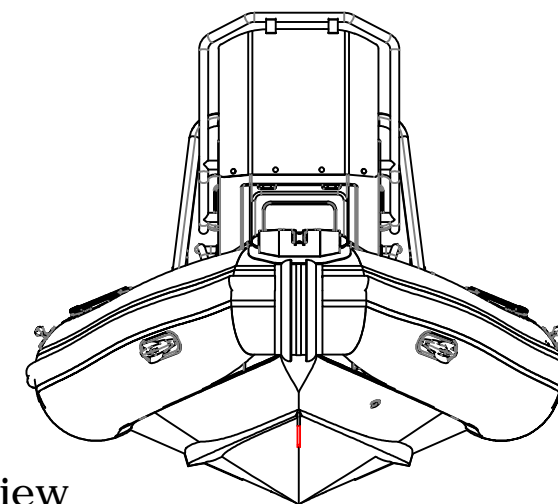
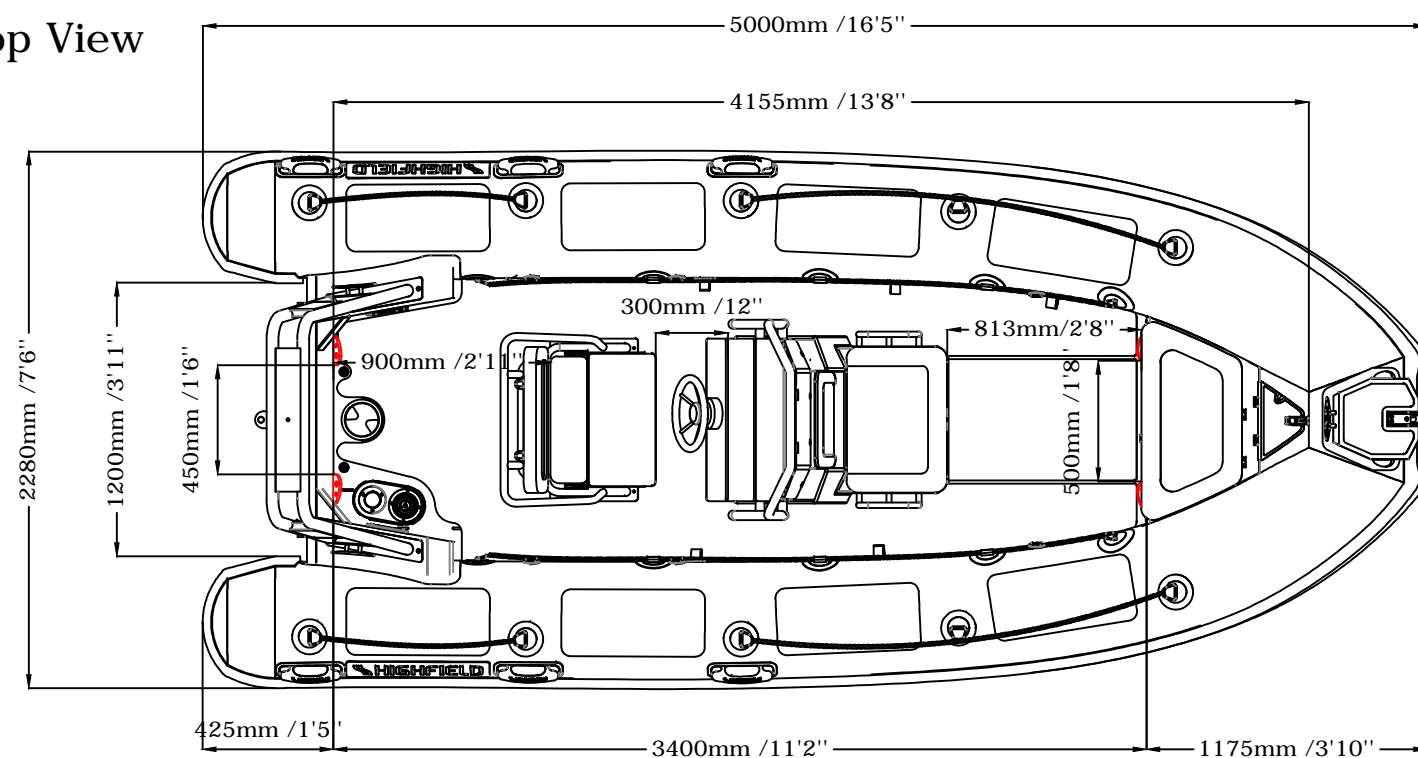

Front View

SPECIFICATIONS AND MAXIMUM CAPACITIES (Subject to change without notice. Tolerances: Dimensions +/-3% Weight +/-5%)

MODEL	ISO 6185 PART	ISO 6185																						
			KG	LB	#	KG	LB	Length	Maximum		Maximum Speed			KG	LB	Wet Weight (Approximate) 100HP (74.60KW) +Fuel		AIR CHAMBERS	PSI	BAR				
			KG	LB	KT	MPH	KW		HP	KW	HP	KT	MPH	Km/h	KG	LB								
OM500	3	C	1051	2317	10	750	1653	L	207.6	458	74.60	100	67.14	90	/	/	/	441	972	713.85	1574	6	3.63	0.25

Weight includes: console, seat, rollbar