

# PATROL 600SB

# SPECIFICATIONS

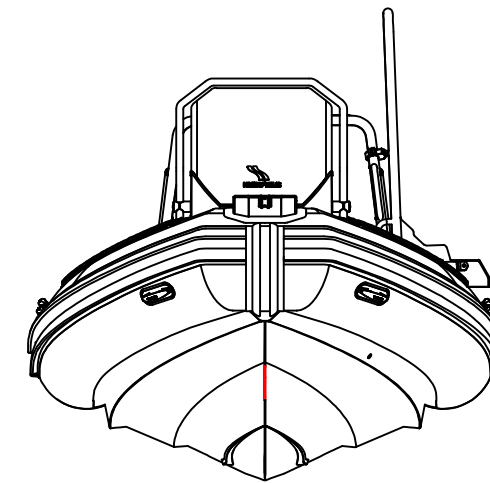
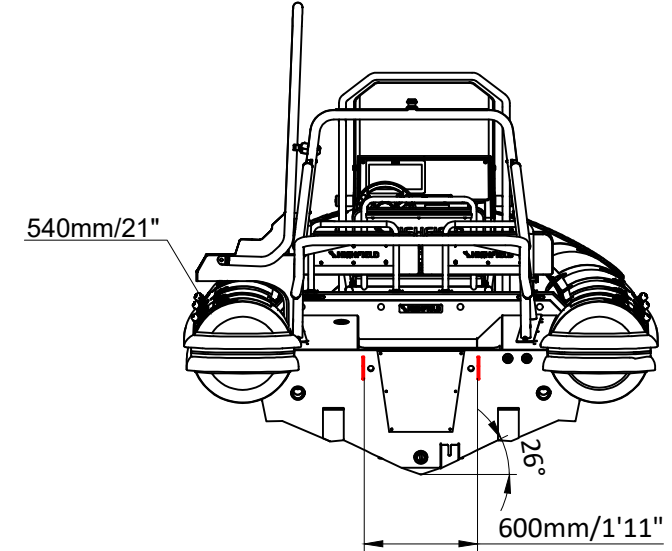
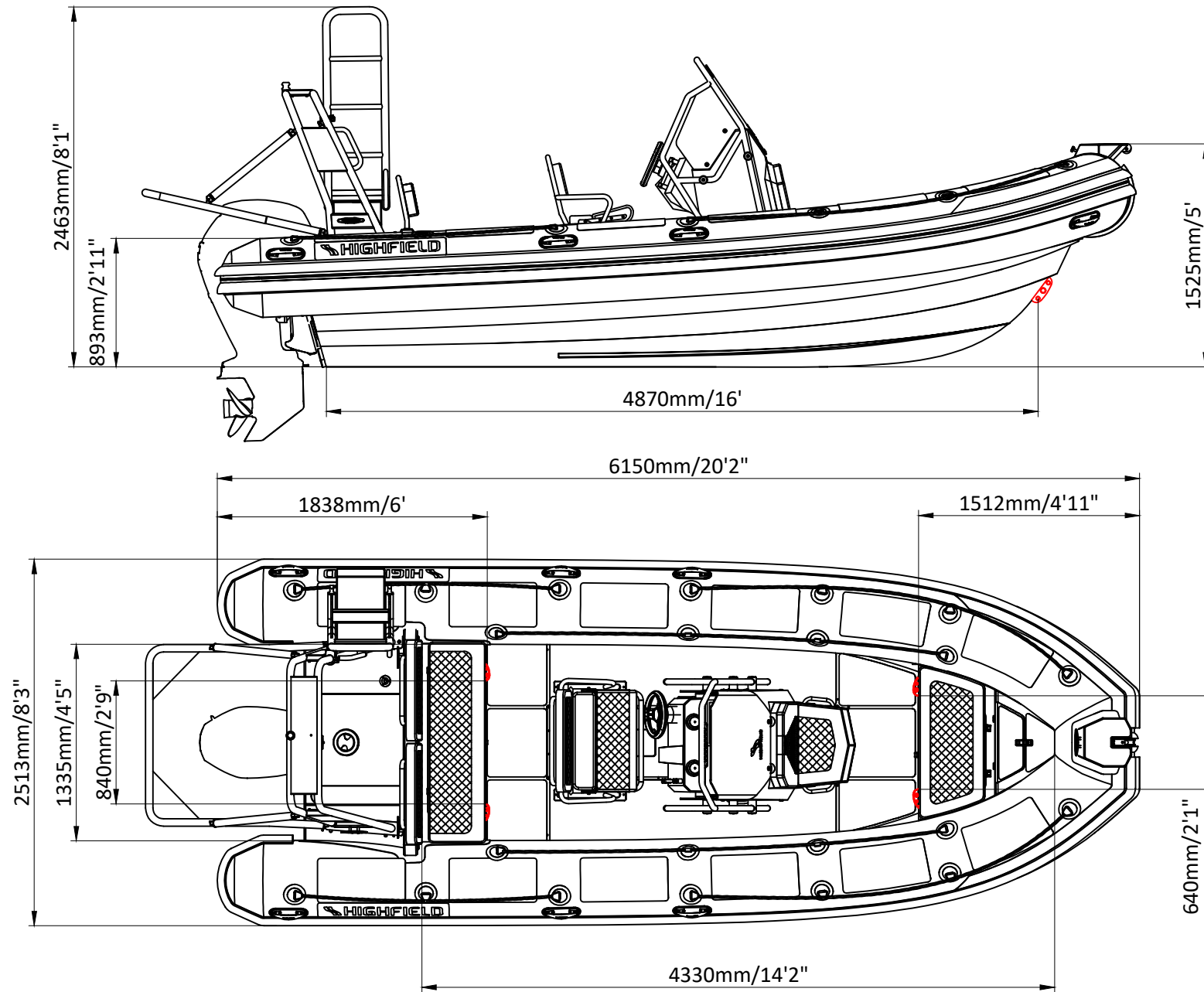

SPECIFICATIONS AND MAXIMUM CAPACITIES (Subject to change without notice. Tolerances: Dimensions ±2.5% Weight ±5%) Note: red means lifting eyes.

MODEL	ISO 6185 PART	ISO 6185	Person		#	Person		Shaft	Outboard Engine				Engine guard		Rear tow post		Rollbar with ladder		Fuel tank Capacity		Wet Weight (Approximate) 150HP (112KW) +Fuel		AIR CHAMBERS	Pressure			
			KG	LB		KG	LB		Max power	Max weight	KG	LB	KG	LB	KG	LB	L	GAL	KG	LB	PSI	BAR					
									KW	HP	KG	LB															
PA600 SB	3	C	1200	2646	15	1125	2480	XL	112	150	271	597	733	1616	15	33	19	42	43	95	140	37	1106	2438	6	3.63	0.25

Boat weight includes: console, seat